

TGK1 Series Control and Protection Switchgear



1 Overview

1.1 Products and applications

TGK1 series control and protection switchgear (CPS) (hereinafter referred to as "switch") is mainly used in AC 50Hz (60Hz) circuit with rated working voltage up to 690V, rated working current 1A to 125A, controller setting current 0.4A to 125A, and control motor power 0.12kW to 55kW for powering on, carrying and breaking the current under normal conditions (including the specified overload conditions), and also can power on and carry the current for some and break the current under the specified abnormal conditions (such as short-circuit).

The switch adopts a modular integrated structure, integrating main functions of many parts such as circuit breakers, contactors, overload relays, starters, and isolators with remote automatic control and local direct manual control, panel indication and electro-mechanical signal alarm, overvoltage and undervoltage protection and open-phase and phase-loss protection functions.

The switch has advantages of small volume, high reliability, high short-circuit breaking capacity, and short flashover distance with inverse-time overload long delay, short-circuit short delay, instantaneous short-circuit protection, and fast short-circuit protection. Functions can be selected as required to provide complete protection for various motor starting and control circuits and power distribution circuits with accurate and reliable actions.

TGK1 series products are mainly composed of body housing, electromagnetic transmission mechanism, operating mechanism, main circuit contact group, intelligent trip unit, and auxiliary contact for local or remote power-on and power-off of control circuit.

TGK1 series switches are widely used in the following occasions or systems:

- Power distribution and motor protection and control systems in fields such as iron & steel, petrochemical, mining, ports, and transportation;
- Power distribution and motor protection and control systems in large venues such as urban streets, hospitals, schools, cultural and sports centers, and commercial centers;
- Power distribution and motor protection and control systems for data information and communication, water supply and drainage, and fire protection;
- Power distribution and motor protection and control systems in commercial and residential buildings, and infrastructure;
- Motor control centers (MMC) and power distribution centers of various units;
- Widely used in power distribution lighting circuits to provide circuit control and protection;
- Widely used in the fire protection system of buildings to provide control and protection for circuits such as fire water pumps and fire fans;
- Control and protection of power distribution circuits and motors in various professional equipment.

1.2 Standard

IEC60947-6-2 Low-voltage switchgear and controlgear - Part 6-2: Multiple function equipment - Control and protective switching devices

2 Type Designation

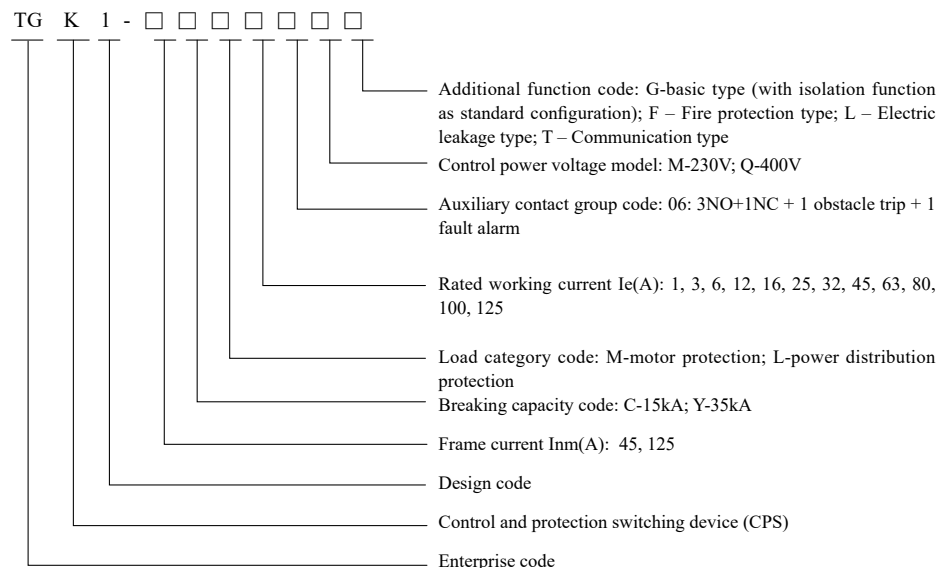

TGK1 Series Control and Protection Switchgear

3 Technical Parameters

3.1 Main circuit parameters

Table 1

Rated power voltage Ue	TGK1-45									TGK1-125			
Rated working voltage Ue(V)	400、690/50Hz												
Rated insulation voltage Ui(V)	690									690			
Rated impulse withstand voltage Uimp(kV)	4									6			
Resistive current Ith(A)	16					45				80		125	
Rated working current Ie(A)	1	3	6	12	16	25	32	45	63	80	100	125	
Use category	AC-43, AC-44												
Number of poles	3P												

3.2 Controller setting current

Table 2

Frame grade	Rated working current Ie(A)	Rated current of controller Iet(A)	Overload setting current Ir1 range (A)	Controllable motor power Pe(kW) (400V)
45	1	1	0.4 ~ 1	0.12 ~ 0.3
	3	3	1.2 ~ 3	0.37 ~ 1.2
	6	6	2.4 ~ 6	1.0 ~ 2.7
	12	12	4.8 ~ 12	2.2 ~ 5.5
	16	16	6.4 ~ 16	3.0 ~ 7.5
	25	25	10 ~ 25	5.0 ~ 12
	32	32	12.8 ~ 32	6.5 ~ 15
125	45	45	18 ~ 45	9.0 ~ 22
	63	63	25 ~ 63	12 ~ 30
	80	80	32 ~ 80	15 ~ 37
	100	100	40 ~ 100	22 ~ 45
	125	125	50 ~ 125	27 ~ 55

3.3 Control electromagnet action conditions

Table 3

Rated control power voltage Us	Appoint action	Action voltage range
M:AC230V Q:AC400V	TGK1 closed reliably	(85% ~ 110%) Us
	TGK1 disconnected or released	(20% ~ 75%) Us

3.4 Electrical life

Table 4

Model		TGK1-45	TGK1-125
Electric life (10,000 times)	AC-43	100	30
	AC-44	3	2
Mechanical life (10,000 times)		1,000	300
Work system level (intermittent work system)		300 load factor 40%	120 load factor 25%

TGK1 Series Control and Protection Switchgear

3.5 Time-current action characteristics

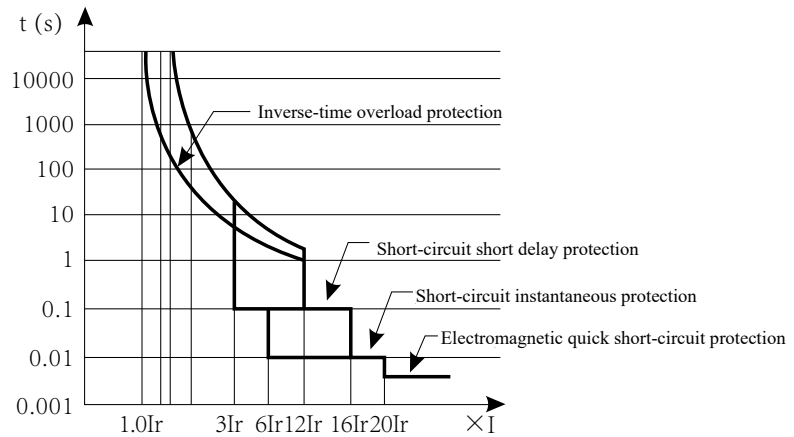

4 Operating Conditions

4.1 Ambient air temperature

The upper limit does not exceed $+40^{\circ}\text{C}$; the lower limit is not below -5°C ; the daily average does not exceed $+35^{\circ}\text{C}$; when the ambient air temperature is out of the range, the user shall contact the manufacturer for agreement.

4.2 The altitude of the installation site does not exceed 2,000 meters. If exceeded, select the model according to the altitude correction factor.

4.3 Atmospheric conditions

When the ambient air temperature is $+40^{\circ}\text{C}$, the relative humidity of the atmosphere does not exceed 50%; a higher relative humidity at a lower temperature is allowed. When the monthly average minimum temperature is $+25^{\circ}\text{C}$, the monthly average maximum relative humidity is 90%, and special measures must be taken for condensation on the product due to temperature changes.

4.4 Pollution degree: 3

4.5 Installation category: Class III

4.6 Protection grade: IP20

4.7 EMC: Environment B

4.8 Non thermal memory electronic type

TGK1 Series Control and Protection Switchgear

5 Setting and Operation

5.1 Function parameters and factory setting

Intelligent controller function parameters setting: The protection characteristics of TGK1 switch see Table 5

Table 5

Function	Parameter setting	Time-delay set	Factory preset	User settable parameter	Fault status output		
					Basic type	Fire protection type	
Overload protection	(0.4 ~ 1)Ie	Protection curve code	F1	(0.4 ~ 1)Ie	Time-delay trip	Delay alarm	
Short-circuit short delay protection	(3 ~ 12)Ir+(0)	0.3 ~ 0.6s	8Ir/0.4s	(3 ~ 12)Ir+(0)	Time-delay trip	Delay alarm	
Short-circuit instantaneous protection	45 type	-	14Ie	(6 ~ 16)Ie	Instantaneous trip	Trip	
	125 type		12Ie	(6 ~ 14)Ie			
Unbalance (break phase and phase loss) protection	(20% ~ 80%)+(0)	1 ~ 40s	30%/10s	(20% ~ 80%)+(0)	Delay trip	Delay alarm (trip)	
Undercurrent protection	(0.2 ~ 0.8)Ir+(0)	1 ~ 60s	(0)	(0.2 ~ 0.8)Ir+(0)	Delay trip	Delay alarm	
Undervoltage protection	Us230V	(154V ~ 198V)+(0)	1 ~ 30s	176V/10s	(154V ~ 198V)+(0)	Delay trip	Delay alarm (trip)
	Us400V	(266V ~ 342V)+(0)	1 ~ 30s	304V/10s	(266V ~ 342V)+(0)		
Overvoltage protection	Us230V	(230V ~ 286V)+(0)	1 ~ 30s	264V/10s	(230V ~ 286V)+(0)	Delay trip	Delay alarm
	Us400V	(400V ~ 494V)+(0)	1 ~ 30s	456V/10s	(400V ~ 494V)+(0)		
Start delay	(0 ~ 99s)+(0)	0 ~ 99s	3s	(0 ~ 99s)+(0)	During start delay, some protections will be shielded such as short-circuit instantaneous trip.		
Jam delay	(5 ~ 9)Ir+(0)	1 ~ 50s	(0)	隐藏菜单	Delay trip	Delay trip	
Residual current protection	(30 ~ 500mA)+(0)	0.1 ~ 1s	100mA	(30 ~ 500mA)+(0)	Trip	Alarm	

Note: As model functions, communication and leakage are optional; communication products adopt RS485 communication line, RJ45 interface, and Modbus protocol.
 Overload protection setting curve (1.5I_{r1} action time, s): F0 (with overload protection deactivated), F1 (51), F2 (98), F3 (144), F4 (200)
 For overvoltage / undervoltage protection of controller, its power signal is from the auto-control terminal U_s (A1-A2); residual current set as gear format: 30, 50, 75, 100, 150, 200, 300, 500 (mA). Fire protection type, under-voltage fault output is a delay alarm; when the voltage is lower than 132V (230V specification) or 228V (400V specification), trip will occur. The function parameter in the table is (0), indicating that this function is off.

5.2 Controller panel description

TGK1 should set the long-time delay and short-time delay setting current to the required value according to the line load current controlled and protected before the main circuit is powered on. After power on, the nixie tube will light up displaying the auxiliary current voltage value and the monitored circuit operating current values of three phases (A, B, C) in the cycle way.

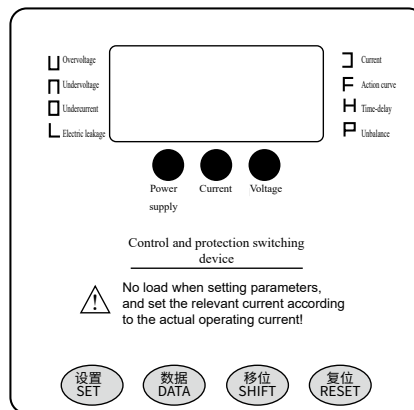

Set key: when the load is not running, press this key to enter the parameter setting state

Data key: modify the flashing word bit with the level difference of 1 (0 to 9 cycles)

Shift key: select the set word bit in the set state, and the selected word bit is in the flashing state

Reset key: After the parameter setting is completed, press this key to save parameters to put into the monitoring operation

TGK1 Series Control and Protection Switchgear

5.3 Run operation

When TGK1 is connected to the working power supply, the LED displays the voltage value, and can be served as a voltmeter; the last three bits display the voltage value.

TGK1 can be served as an ammeter during operation to display three-phase current operation cyclically.

During the operation of TGK1, the power indicator is always on for basic products; the power indicator will flash for fire protection products.

Fault query: Run TGK1 under non-load; with "data key" pressed, compare with the panel fault type symbol, and view the last fault type; when the voltage value is displayed, it means that TGK1 has exited fault query and puts into normal monitoring operation; restart TGK1 to exit the fault query.

5.4 Controller menu (protection parameter setting)

5.4.1 Controller menu

Controller menu level: open setting menu, hidden setting menu;

Open setting menu: Users can set function parameters as required (refer to Table 6);

Hidden setting menu: Users can set basic/firefighting change-over, communication address, baud rate and self-tuning functions.

One-key recovery operation: In case of parameter setting error, perform this operation, and restore the factory setting parameters of controller (Table 6 Factory preset values);

Self-tuning operation: After the load running is stable, perform this operation; the controller will automatically set the current setting according to the circuit parameters.

Warning: Do not enter the hidden setting menu and calibration menu to avoid setting disorder.

5.4.2 Protection parameter setting

When the motor starts and runs, the setting key will be invalid;

Open menu setting: During operation under non-load, press the set key to select the setting type, and press the Shift keys in turn to select data shift and press the data key to modify data;

Hidden menu setting: During operation under non-load, long-press data key and shift key (4s) to enter the hidden menu; press the set key to select the setting type, press the Shift keys in turn to select data shift and press the data key to modify data;

After setting parameters, press the set key to enter the next set state until all are finished;

Setting will be ignored for unrequired option. All parameters are set, press the Reset key to exist the setting state, keep the setting, and display the voltage value.

5.4.3 One-key recovery parameter operation

During operation under no-load, press the set key continuously to select the factory set, press the data key to set to YES, and press the Reset key to complete one-key recovery (initialization).

5.4.4 Auto-tuning parameter operation

Long press the number key and shift key (4s) to enter the hidden menu to display the basic / fire control switching; continuously press the Set key to start the self-setting mode ; press the Data key to adjust to YES, and press the Reset key to exit the menu;

If the product is of the basic type, the power indicator flashes and enter the auto-tuning state. The indicator light is always on to indicate that the auto-tuning is set successfully, and the switch enters the normal working state; if the product is of the fire protection type, the power light is always on and enter the auto-tuning state. The power light flashes to indicate that the auto-tuning is set successfully and the switch enters the normal working state; if the indicator light is off, it indicates that the auto-tuning fails to set; at this time, press the Reset key or restart the switch to return to the original state.

Table 6

Operation sequence	Display content	Code definition	Setting range	Display content
Press the set key for the first time	□000	Long-time delay setting current	(0.4 ~ 1) Ie	Customer requirements
Press the set key for the second time	H05	Start-time delay	0 ~ 99s	3s
Press the set key for the third time	F	Overcurrent inverse time protection action	Selected from the range of No. 1 to 4	F1
Press the set key 4th time	P 30	Percentage of three-phase unbalance	(20% ~ 80%)+(0)	30%
Press the set key for the 5th time	□	Overvoltage value	(230V ~ 286V)+(0)	264V
Press the set key for the 6th time	□	Undervoltage value	(154V ~ 198V)+(0)	176V
Press the set key for the 7th time	L	Leakage current value code	Select from Item 0 to 8	Customer requirements
Press the set key for the 8th time	□	Undercurrent value	(0 ~ 0.8) Ir+(0)	(0)
Press the set key for the 9th time	□ □ □	Factory settings	NO or YES	NO

TGK1 Series Control and Protection Switchgear

Table 7

Menu display	Fault type	Fault parameter
□ 67.5	Overload	Current 67.5A
┘ 483	Short-circuit short-time delay	Current 483A
⊐ 650	Short-circuit transient	Current 650A
⊐ 100	Phase loss	Phase loss
⊐ 38	Three-phase unbalance	38%
□ 15	Undercurrent	Current 15A
┘ 268	Overvoltage	Voltage 268V
⊐ 170	Undervoltage	Voltage 170V
Return	/	/

5.5 Operation handle (panel description)

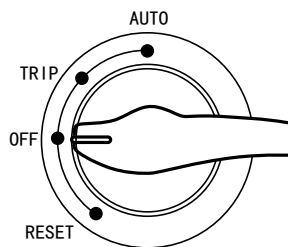

Turn on AUTO: (automatic control position); the switch is used to power on the electromagnet coil, and to turn on / off the control power supply to realize the remote automatic control.

Trip TRIP: When trip in case of a fault, the switching mechanism will work to trip, the main contact is open, and electromagnet coil circuit is power off.

Power off OFF: In the manual mode, the electromagnet coil is power off, and main contact of switch is in the OPEN position.

Re-trip RESET: Turn the operating knob to reset the tripped switching mechanism normally for trip again.

Isolation state: In the OPEN position, pull out and lock the isolation insert strip; at this time, the product is at the disconnected isolation state, and the handle is not available.

6 Installation and Use

Before installing the switch, check that the operating knob can work normally and is in the OFF position. "AUTO" is the main circuit power-on state, and "TRIP" is the free trip position. This state is the free trip position due to line failure. The switch can only be operated after the line fault is cleared by the appointed person. "OFF" is the main circuit OPEN position. The free-trip switch can only be reset and re-tripped by turning the operating knob to the "RESET" position.

Before the switch is installed and used, carefully check whether the power supply voltage of the coil and accessories is consistent with the product instruction and with the actual control circuit. With the coil powered (85%~110%) Us, when the knob is turned to the "AUTO" position, the electromagnet is reliably attracted, and when the knob is turned to the "OFF" position, the electromagnet is reliably released.

The operating current setting value of the switch release has been set at the factory, and can be adjusted by user according to actual needs.

The switch has the functions of overload and overcurrent, open-phase and phase loss, overvoltage and undervoltage protection, and an alarm display can be given by the indicator light.

TGK1 can run continuously after breaking the short-circuit current, but the switch shall be checked and the switch working status shall be confirmed.

TGK1 Series Control and Protection Switchgear

6.1 Common troubleshooting

Table 7

Menu display	Fault type	Fault type	Fault parameter
1	With the power supply connected, the switch does not work	① Check whether the operating knob is in the "AUTO" position ② Check whether the A1, A2 control power supply works normally	Turn the operating knob to the "AUTO" position and correctly connect to the control power supply
2	Turn on the power, and found the switch coil burns out	Check whether A1, A2 control power supply is connected wrongly or short circuit	Check the control circuit, or replace the switch
3	The switch is not self-locked	① Check auxiliary self-lock contacts ② Check A1, A2 control power supply voltage	Correctly connect the auxiliary circuit; for auxiliary circuit failure, replace the switch
4	The switch is turned on but the motor does not work	Check the power supply circuit and load	Check and repair the circuit and connect to the power supply correctly
5	Motor start, switch protection	Check 95, 98 auxiliary circuit status or handle position, and query the cause of the fault trip	Check and repair the load circuit (short circuit), adjust the load and switch parameters; or replace the switch
6	Load running for a period of time, switch protection	Switch intelligent controller protection, query fault record, check circuit	Check and repair the circuit; adjust and set parameters according to the load or replace the switch
7	The motor is burned out and the switch is not protected	Check the switch parameter setting, view the fault, check the circuit	Re-set the parameters according to the load, check and repair the circuit or replace the switch

6.2 Switch installation diagram (shown below)

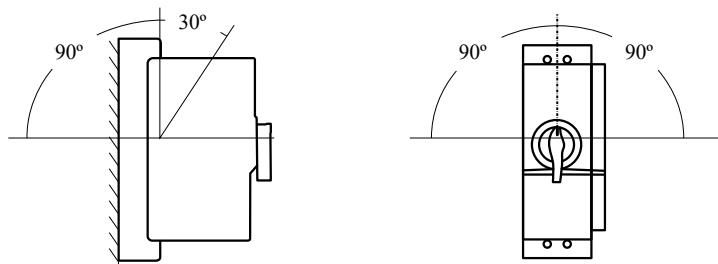

6.3 Outline and installation dimensions

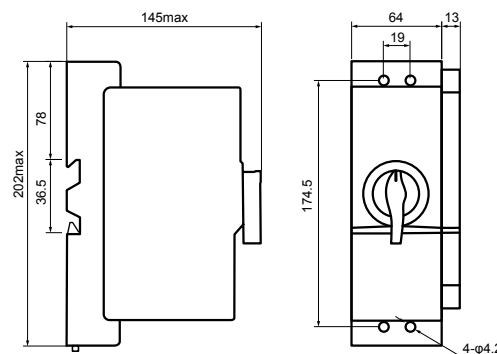

TGK1-45 control and protection switchgear

TGK1 Series Control and Protection Switchgear

7.3 Manual panel + local control + remote control

Manual panel + local control + remote control

Secondary power supply	Power protection	Power signal	Local and remote manual control	Auxiliary signal			Fault signal		External signal		Signal power
				Self-lock	Run	Stop	Stop	Alarm	Stop	Run	

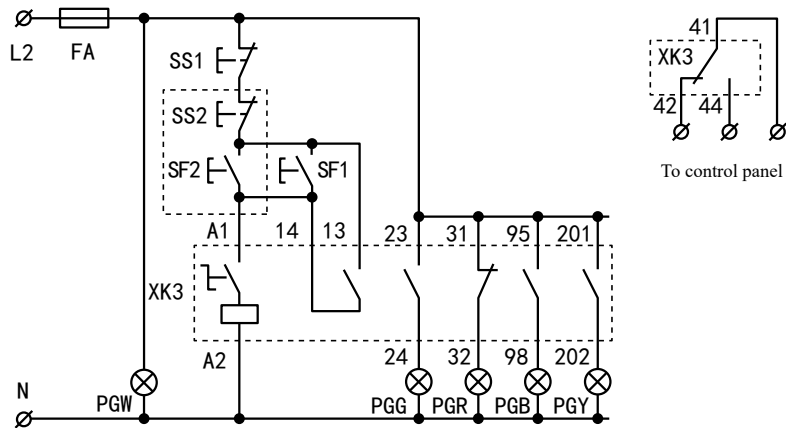

Note: This diagram is suitable for a single device in normal operation for various motors, with local and remote simultaneous control.

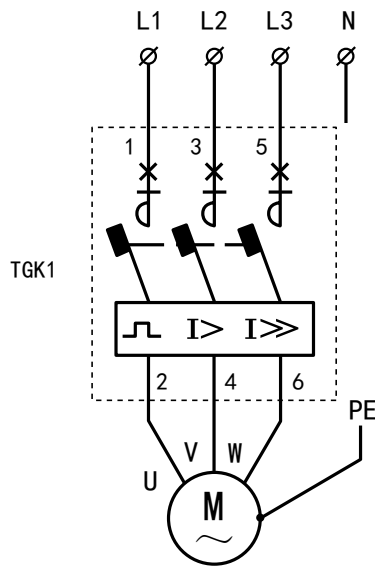

TGK1 Series Control and Protection Switchgear

8 Precautions

To control high-power motor (11kW and above), the starting torque, current multiples, voltage drop, and circuit capacity shall be considered comprehensively by user, and the appropriate voltage-reduction starting method is selected. The general specification requires that the voltage drop limit does not exceed 80% of the rated value and the starting current multiple should not exceed (4 ~ 5) times to allow the normal startup under the appropriate load and to guarantee the reliable action of the TGK1 electromagnet.

The exposed parts of the external connecting wires of the switch incoming and outgoing terminals shall be wrapped with insulation.

The product should be protected from rain and snow during transportation and storage. The storage environment must meet the following conditions: The mean daily temperature is +25°C, the relative humidity is not less than 90%, and the ambient temperature is not higher than +40°C and not lower than -5°C.

9 Ordering Notice

Please specify the following items when selecting TGK1 switch, and further specify the use conditions or use requirements if required:

Product name and model

Rated current of switch, and type and rated current of intelligent controller

Control power voltage of electromagnet coil

Required additional functions