

TGLD Series Automatic Transfer Switching Equipment

1 Overview



TGLD series automatic transfer switching equipment is suitable for AC 50Hz three-phase four-wire dual-circuit power supply grid with rated working voltage AC400V and rated current up to 3200A to disconnect the load circuit from one power supply and connect it to the other power supply. This transfer switching equipment has automatic action and optional manual operating functions. When any deviation of common power supply is detected, ATSE can transfer the load to the standby power supply from the common power supply automatically. If the common power supply recovers to the normal state, the load can be returned to the common power supply automatically.

2 Type Designation

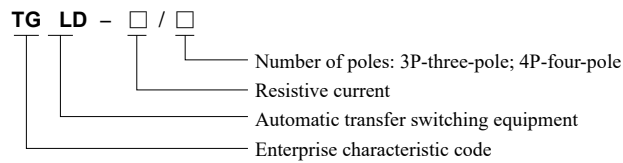

3 Technical Parameters

Table 1

Model	TGLD-100	TGLD-160	TGLD-250	TGLD-400	TGLD-630
Current spec. (A)	16, 20, 25, 32, 40, 50, 63, 80, 100	100, 125, 140, 160	160, 180, 200, 225, 250	250, 315, 350, 400	400, 500, 630
Rated operating voltage (U _e)	AC400V 50Hz				
Rated insulation voltage (U _i)	690V				
Rated impulse withstand voltage (U _{imp})	8kV				
Rated short-time withstand voltage ICW (kA)	5/30ms	10/30ms			12.6/60ms
Rated short-circuit making capacity I _{cm} (kA)	8	17			25.2
Rated short-circuit limit current I _q (kA)	Front fuse 50				
Number of poles	3P, 4P				
Usage category	AC-33iB				
Electrical level	Level PC				
Electromagnetic compatibility environment	B environment				
Pollution degree	3				
Installation method	Vertical and fixed				
Wiring method	Wiring via screws				
Operation method	Auto / Manual / Electric button on cabinet door				
Screw tightening torque (N·m)	12	20	20		
Screw failure torque (N·m)	15	50			
Mechanical life(times)	9,000 (*)			6,000 (*)	4,000 (*)
Electrical life (times)	3,000 (*)			2,000 (*)	2,000 (*)
Max. number of conductors allowed	1 piece			2 pieces	
Switch position	Common position (I), standby position (II), OFF position (0)				
Pollution degree	Level 3				
Protection grade	IP00				
Contact transfer time (s)	0.95±30%			0.30±30%	
Operating transfer time (s)	2.9±10% TGLD-100(Economical type): 1.7±10%			1.1±10%	
Return time (s)	2.9±10% TGLD-100(Economical type): 2±10%			1.3±10%	
Power-off time(s)	0.93±30%			0.3±30%	
Power voltage deviation range	Undervoltage transfer: 160V±10%				
Voltage hysteresis V	Undervoltage fixed value (default: 160V) +20V±10%				
Control feature	Voltage loss, undervoltage, phase loss switching				
Rated control power voltage (Us)	AC230V 50Hz				
Controller installation method	Integrated				
Normal working range	85%U _e ~ 110%U _e				
Return condition	Automatic transfer automatic recover (Automatic transfer and non-automatic recover function can be customized)				
Controller power (W)	≤5	≤10			

Note: (*) maintainable

TGLD Series Automatic Transfer Switching Equipment

Table 1, continued

Model	TGLD-1000	TGLD-1250	TGLD-1600	TGLD-2000	TGLD-2500	TGLD-3200
Current spec. (A)	630,700 800,1000	1250	1600	2000	2500	3200
Rated operating voltage (Uc)	AC400V 50Hz					
Rated insulation voltage (Ui)	1000V					
Rated impulse withstand voltage (Uimp)	12kV					
Rated short-time withstand voltage ICW (kA)	32/60ms			55/60ms		
Rated short-circuit making capacity Icm (kA)	67.2			121		
Rated short-circuit limit current Iq (kA)	Front circuit breaker			/		
	90			/		
Number of poles	3P、4P					
Usage category	AC-33iB					
Electrical level	Level PC					
Electromagnetic compatibility environment t	B environment					
Pollution degree	3					
Installation method	Vertical and fixed					
Wiring method	Wiring via screws					
Operation method	Auto / Manual / Electric button on cabinet door					
Screw tightening torque (Nm)	25					
Screw failure torque (Nm)	50					
Mechanical life(times)	4,000 (*)			2,500 (*)		
Electrical life (times)	2,000 (*)			500 (*)		
Max. number of conductors allowed	4 pcs			4 pcs		
Switch position	Common position (I), standby position (II), OFF position (0)					
Pollution degree	Level 3					
Protection grade	IP00					
Contact transfer time (s)	0.6±30%			0.85±30%		
Operating transfer time (s)	3±10%			2.9±10%		
Return time (s)	3±10%			2.9±10%		
Power-off time (s)	0.60±30%			0.85±30%		
Power voltage deviation range	Undervoltage transfer: 160V±10%					
Voltage hysteresis V	Undervoltage fixed value (default: 160V) +20V±10%					
Control feature	Voltage loss, undervoltage, phase loss switching					
Rated control power voltage (Us)	AC230V 50Hz					
Controller installation method	Integrated					
Normal working range	85%Ue ~ 110%Ue					
Return condition	Automatic transfer automatic recover (Automatic transfer and non-automatic recover function can be customized)					
Controller power (W)	≤10					

Note: (*) maintainable

TGLD Series Automatic Transfer Switching Equipment

4 Operating Conditions

- 4.1 Ambient air temperature: The upper limit of ambient air temperature is +40°C, and the lower limit is -5°C; the mean temperature within 24h does not exceed +35°C;
- 4.2 Altitude: The altitude at the installation site does not exceed 2,000 meters;
- 4.3 Atmospheric conditions: The relative humidity of atmospheric air does not exceed 50% at the highest ambient temperature +40°C, and a lower relative humidity is allowed at a lower temperature, such as up to 90% at +20°C. Special measures are taken for condensation occurred occasionally due to temperature changes;
- 4.4 Pollution degree: Level 3.

5 Features and Functions

Dual-row combined contact, embedded mechanism, micromotor energy pre-storage and micro-electronics control technology is used with short flashover distance.

Reliable mechanical interlock and electrical interlock are used, and the actuator uses independent on-load isolating switch for safe and reliably operation.

With zero-across technology used, forcedly zeroing can be realized in case of an emergency (powers from two circuits are cut off simultaneously) to satisfy fire linkage needs.

A single motor is used to switch the on-load isolating switch for reliable and smooth switching action and small impact without noise.

The actuator drive motor is powered on only at moment of switching the on-load isolating switch, and the working current is not required at other times during the steady state operation, significantly saving energy.

The on-load isolating switch has a mechanical interlock device to ensure that the common and standby power supplies work reliably without interference each other.

With obvious ON/OFF position indication and padlock functions, realize the isolation between the power supply and the load reliably.

With good safety performance, high automation, and high reliability.

The product has zero position.

With convenient installation, the control circuit adopts the plug-in terminal connection.

Operation function: Manual operation, automatic control operation. Manual operation is prohibited at the Auto state. If manual operation is required, the auto electric lock must be closed to the manual position.

6 Controller Functions (See Table 2)

Table 2

Type	Standard type
Manual and automatic switching mode	■
Common power monitoring	Three-phase monitoring
Standby power monitoring	Single-phase monitoring
Automatic transfer automatic recover	■
Automatic transfer and non-automatic recover	Customized
Grid-grid, grid-power generation	■
Phase loss, volage loss, and undervoltage switching	■
Fire linkage	Active DC24V
External indication signal	Common power, standby power, common ON, standby ON
Cabinet door control	I-O-II

TGLD Series Automatic Transfer Switching Equipment

7 Controller Operation Process (See Fig. 1 and Fig. 2)

Mode 1: Automatic transfer automatic recover (grid-grid)

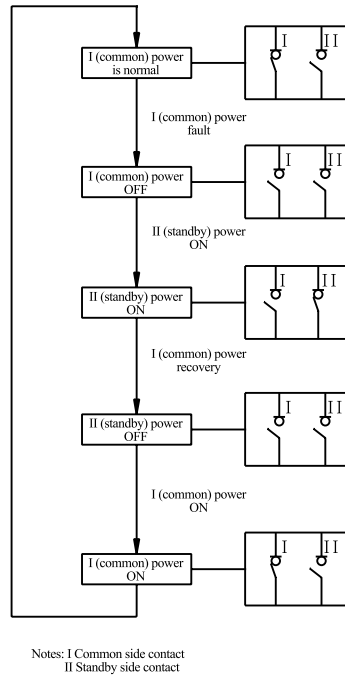

Fig. 1

Mode 2: Automatic transfer automatic recover (grid-power generation)

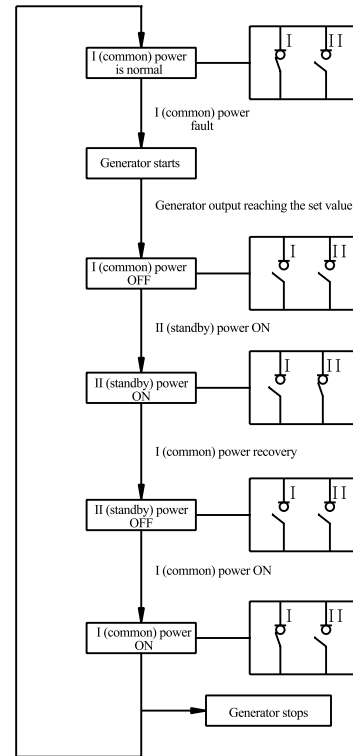
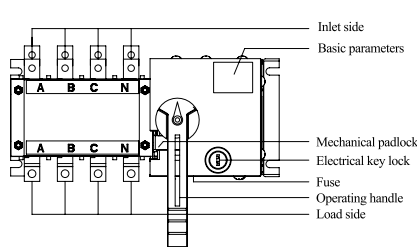
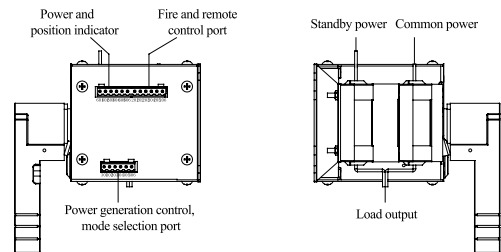

Fig. 2

8 Product Structure



TGLD-100/4 structure diagram



TGLD-100/4 structure diagram

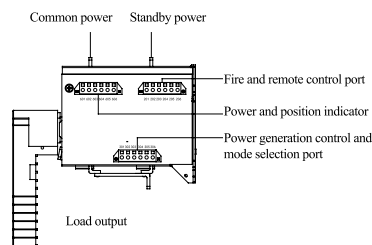

TGLD-160-630/4 structure diagram

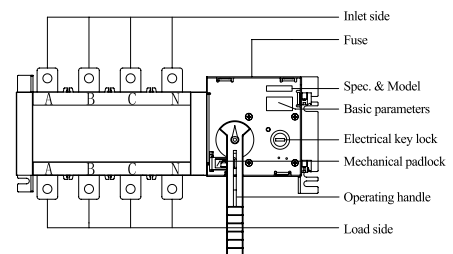

TGLD-100/4 structure diagram

TGLD Series Automatic Transfer Switching Equipment

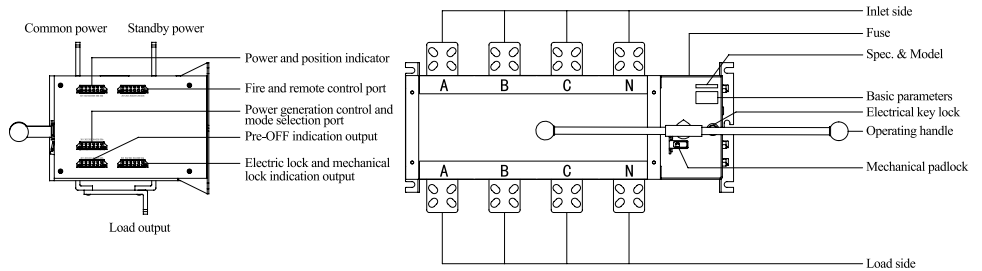

TGLD-100/4 structure diagram

TGLD-160-630/4 structure diagram

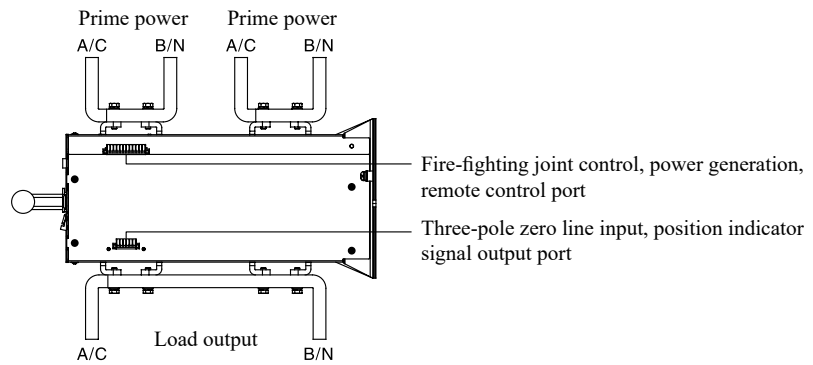

TGLD-3200/4 Structure Diagram

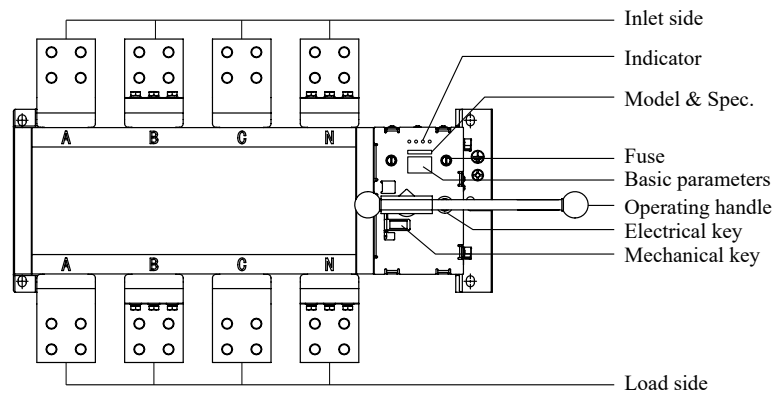

TGLD-3200/4 Structure Diagram

Notes:

- Electric key lock: To control the control line power inside the switch; turning the electric lock to the "Auto" position realizes the auto and remote control operation of switch; turning the electric lock to the "Manual" position realizes the manual operation of switch.
- Operating handle: Close the electric lock when operating the operating handle.
- Mechanical padlock: Before inspection, operate the operating handle to turn the switch to the O position, and pull up and lock the padlock (pulling up the mechanical padlock will cut off the control power inside the switch, so that the switch cannot be turned on and the handle cannot be operated).
- The operating handle is usually removed and stored. It can be used only when the load is disconnected for emergency operation.

TGLD Series Automatic Transfer Switching Equipment

9 Electrical Wiring Diagram

9.1 Main circuit wiring

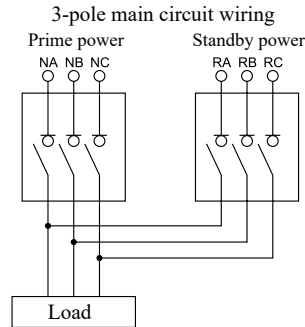

Note: The zero line of 3-pole product is connected to the side terminals 603 and 606; 2000~3200A is connected to 301 and 306 for prime operation

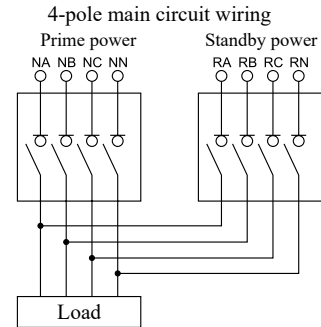

Note: To connect main circuit of product, the upper ports of prime power and standby power shall be connected (SCPD) by user for electrical protection to prevent short-circuit of load, and burns to product and line.

9.2 Auxiliary and control circuit wiring

9.2.1 TGLD-100~630 type

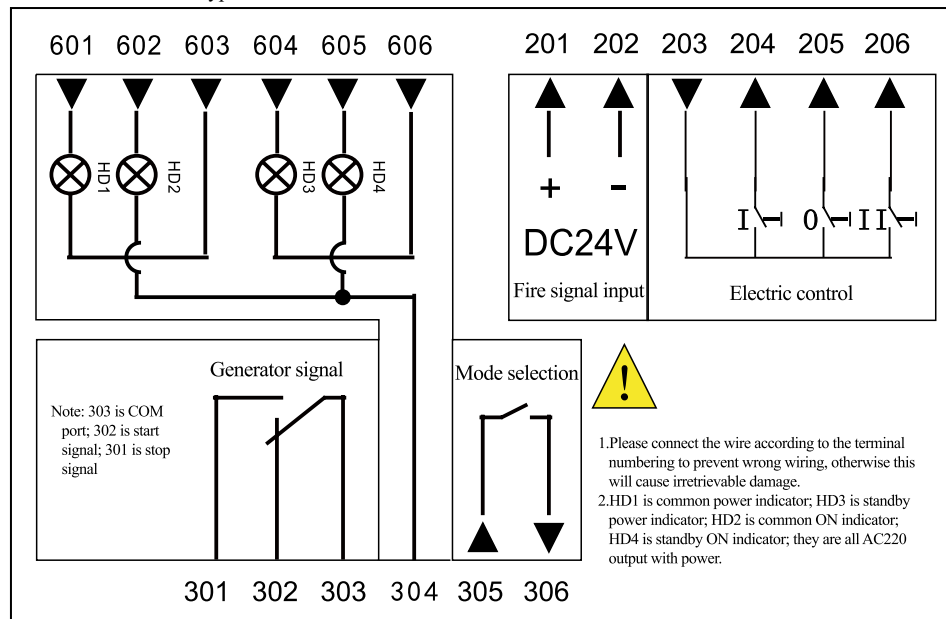

- Common position indicator: 603 and 601 are common power indicators; for 3-pole product, the common working zero line is connected from 603; 602 and 304 are common power ON indicators, and signal outputs are all AC220V output with power.
 - Standby position indicator: 606 and 604 are standby power indicators; for 3-pole product, the standby working zero line is connected from 606; 605 and 304 are standby power ON indicators, and signal outputs are all AC220V output with power.
 - Fire zeroing: 201 is DC24V positive, and 202 is DC24V zero (DC24V is provided by the Fire Center).
 - Electric control (cabinet door control): 203 is common port; 204 is position I; 205 is position 0; 206 is position II.
 - Generator start/stop control: 303 is common port; 302 is start signal; 301 is stop signal.
- f. Mode selection: When 305 and 306 are disconnected: if 204, 205, and 206 input button signals are loose, ATSE will return automatically; when 305 and 306 are short-connected: 204, 205, and 206 input button signals are inching-controlled, and ATSE will not return automatically once the button is release.

TGLD Series Automatic Transfer Switching Equipment

9.2.2 TGLD-1000~1600 type

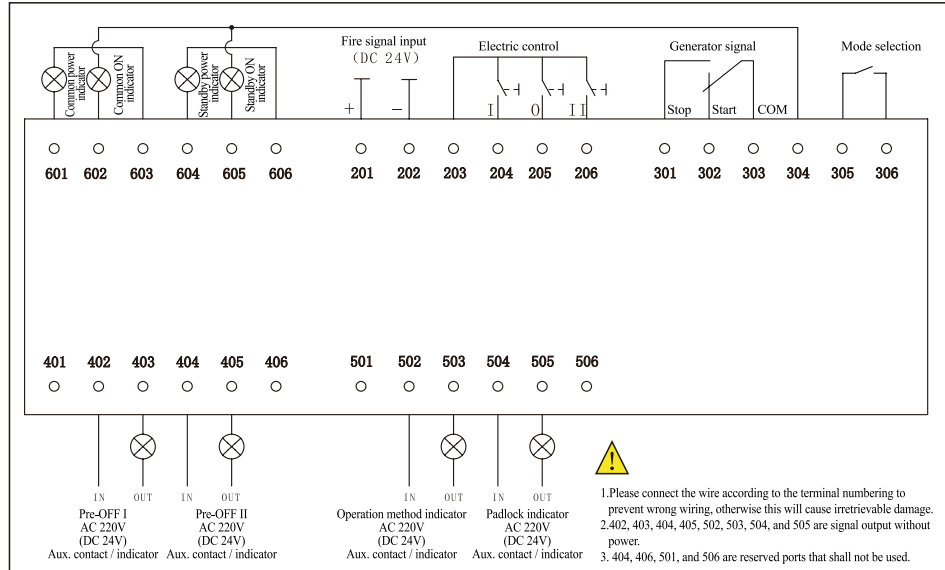

- a. Common position indicator: 603 and 601 are common power indicators; for 3-pole product, the common working zero line is connected from 603; 602 and 304 are common power ON indicators, and signal outputs are all AC220V output with power.
- b. Standby position indicator: 606 and 604 are standby power indicators; for 3-pole product, the standby working zero line is connected from 606; 605 and 304 are standby power ON indicators, and signal outputs are all AC220V output with power.
- c. Fire zeroing: 201 is DC24V positive, and 202 is DC24V zero (DC24V is provided by the Fire Center).
- d. Electric control (cabinet door control): 203 is common port; 204 is position I; 205 is position 0; 206 is position II.
- e. Generator start/stop control: 303 is common port; 302 is start signal; 301 is stop signal.
- f. Mode selection: When 305 and 306 are disconnected: if 204, 205, and 206 input button signals are loose, ATSE will return automatically; when 305 and 306 are short-connected: 204, 205, and 206 input button signals are inching-controlled, and ATSE will not return automatically once the button is release.
- h. 402 and 403 are common pre-OFF indicators; 404 and 405 are standby pre-OFF indicator; signal output without power.
- i. 502 and 503 are padlock indicators; 504 and 505 are mechanical lock indicators; they are all signal outputs without power.

9.3 TGLD-160~1600 wiring terminal wiring operation

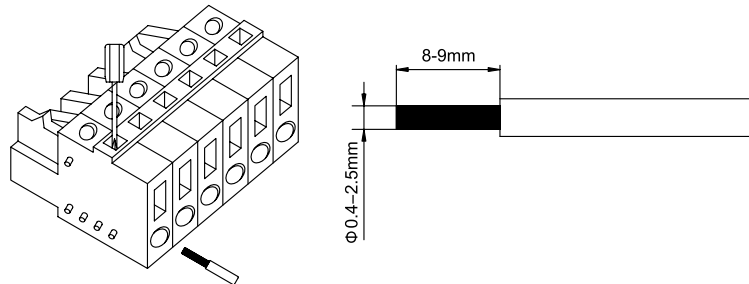

Forcedly press the wire downwards with a small slotted screwdriver for installation, as shown in figure.

TGLD Series Automatic Transfer Switching Equipment

9.4 TGLD-2000~3200 panel indicator and auxiliary and control circuit wiring

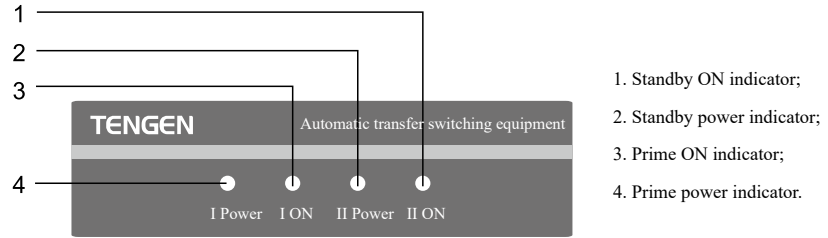

TGLD-3200

9.5 TGLD-2000~3200 Secondary circuit wiring

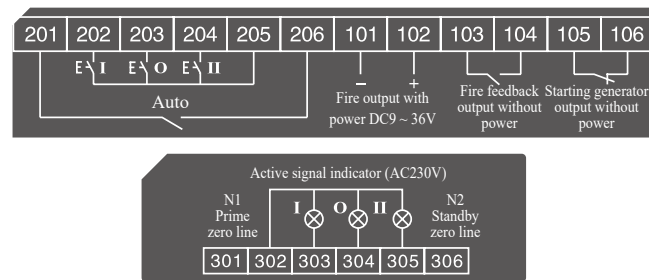

- a. Ports 201 and 206 are short connected for remote control with wires (cabinet door control transfer), and can be powered off automatically;
- b. Port 205 is a remote control COM port;
- c. When ports 205 and 202 detect a closed signal, source “I” power supply works prime and ATSE is transferred to source “I”;
- d. When ports 205 and 204 detect a closed signal, source “II” power supply works prime and ATSE is transferred to source “II”;
- e. When ports 205 and 203 detect a closed signal, one-source or two-source of source “I” power supply or source “II” power supply is prime and ATSE is transferred to the “O” position;
- f. Ports 101 and 102 are fire power supply DC24V (9~36V, 101 is a negative pole and 102 is a positive pole; do not connect them reversely) input, and ATSE executes the fire control linkage function;
- g. Ports 103 and 104 are output feedback signals after ATSE executes the fire control linkage function, and one set of passive signal dry contacts;
- h. Ports 105 and 106 are generator start signals. Connection them to the generator controller can realize the automatic start/stop of generator controller.
- i. Working zero line input for three-pole: 301 is a prime zero line, and 306 is a standby zero line;
- j. 302 is a COM port of position indicator signal;
- k. 303 is an indicator signal of “I” position, with active 220V;
- l. 304 is an indicator signal of “O” position, with active 220V;
- m. 305 is an indicator signal of “II” position, with active 220V;

TGLD Series Automatic Transfer Switching Equipment

10 Outline and Installation Dimensions

10.1 TGLD-100 outline and installation dimensions (Standard type)

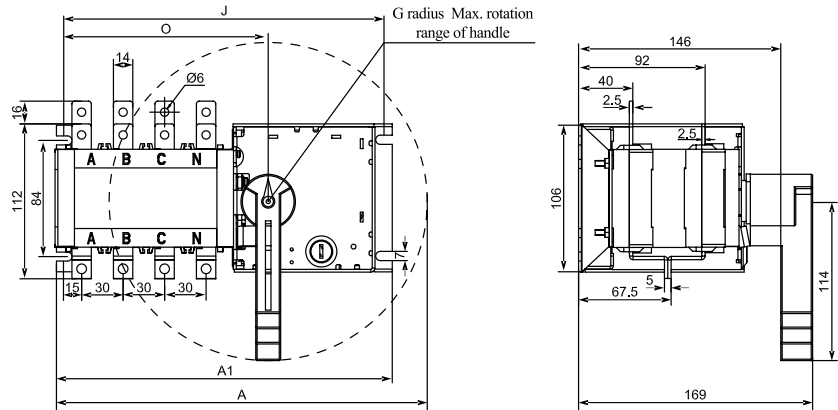

Current	Outline and installation dimensions			
	A	A1	J	O
100/3	235	232	222	113
100/4	270	244	234	143

10.2 TGLD-160~1600 outline and installation dimensions

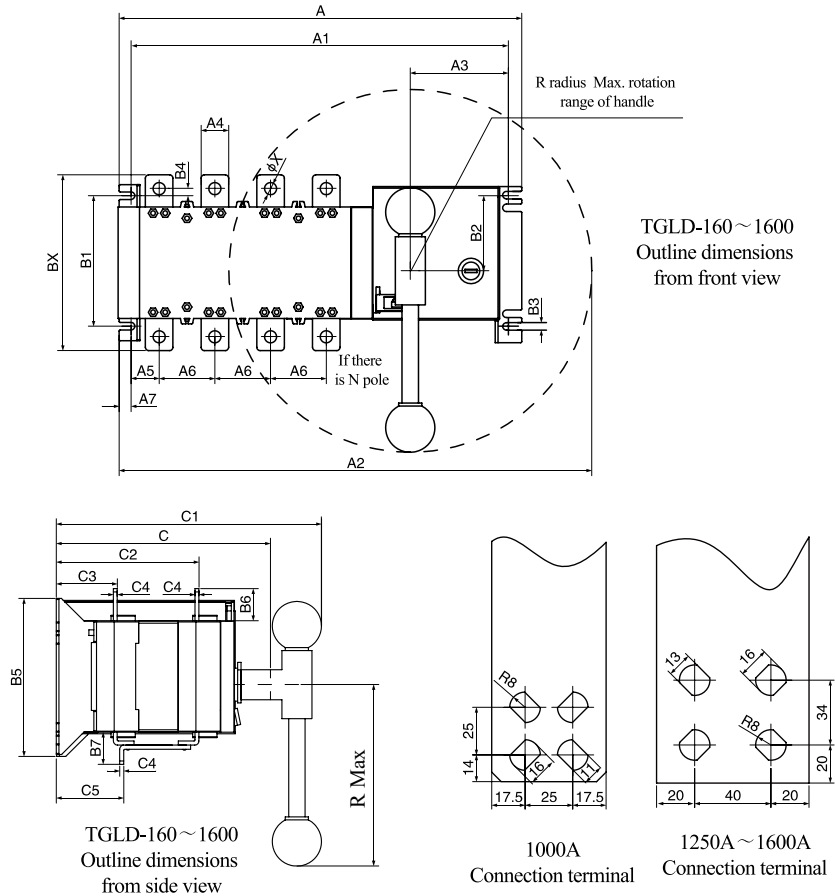

TGLD Series Automatic Transfer Switching Equipment

Outline and installation dimensions table																								
Current	A	A1	A2	A3	A4	A5	A6	A7	BX	B1	B2	B3	B4	B5	B6	B7	C	C1	C2	C3	C4	C5	ΦX	R
160/3	273	263	315	98	20	22	36	9	144	91	52	6	3	141	25	34	194	232	131	60	3.5	63	8.5	150
160/4	308	288	350	98	20	22	36	9	144	91	52	6	3	141	25	34	194	232	131	60	3.5	63	8.5	150
250/3	320	300	362	110	25	28	50	10	177	92	52	6	16	142	30	37	209	240	145	62	3.5	63	11	150
250/4	365	345	412	110	25	28	50	10	177	92	52	6	16	142	30	37	209	240	145	62	3.5	63	11	150
400/3	369	351	600	91.5	32	39	65	9	262	179	95	9	28	218.5	40	62	292	325	196	82	5	82	11	331
400/4	434	416	665	91.5	32	39	65	9	262	179	95	9	28	218.5	40	62	292	325	196	82	5	82	11	331
630/3	369	351	600	91.5	40	39	65	9	272	179	95	9	28	218.5	50	62	292	325	196	82	5	82	12	331
630/4	434	416	665	91.5	40	39	65	9	272	179	95	9	28	218.5	50	62	292	325	196	82	5	82	12	331
1000/3	515	495	870	82	60	65	120	12.5	345	220	116	11	-	250	54	90	340	380	254	110	8	110	-	455
1000/4	635	615	990	82	60	65	120	12.5	345	220	116	11	-	250	54	90	340	380	254	110	8	110	-	455
1250/3	515	495	870	82	80	73	120	12.5	370	220	116	11	-	250	70	102	340	380	254	110	8	110	-	455
1250/4	633	610	990	82	80	73	120	12.5	370	220	116	11	-	250	70	102	340	380	254	110	8	110	-	455
1600/3	515	495	870	82	80	73	120	12.5	370	220	116	11	-	250	70	102	340	380	255	111	10	111	-	455
1600/4	633	610	990	82	80	73	120	12.5	370	220	116	11	-	250	70	102	340	380	255	111	10	111	-	455

Note: BX, B7, and C5 are dimensions of load

10.3 TGLD-2000~3200 Outline and Installation Dimensions (Two-inlet and one-outlet)

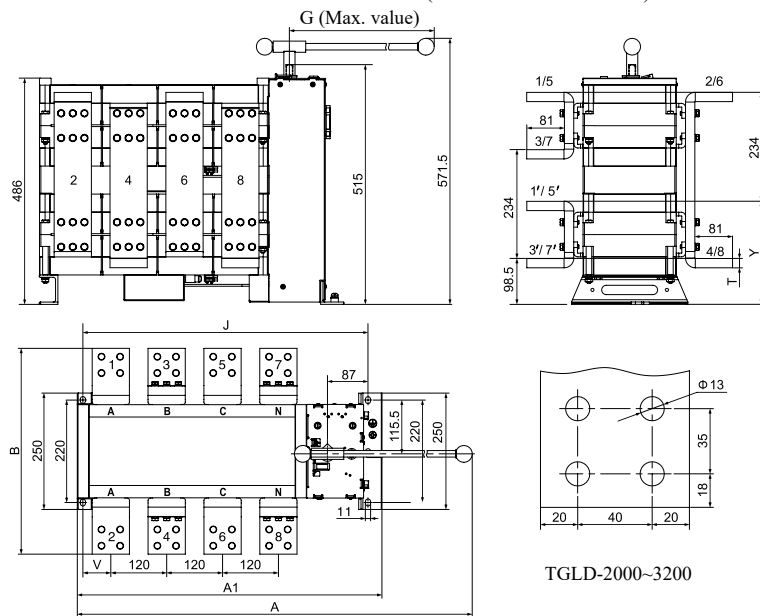

TGLD-2000~3200

Current	Outline and installation dimensions							
	A	A1	B	G	A	A1	B	G
TGLD-2000/3P	785	541	422	360	499	10	56	212
TGLD-2000/4P	1080	655	422	540	613	10	60	212
TGLD-2500/3P	785	541	432	360	499	15	56	217
TGLD-2500/4P	1080	655	432	540	613	15	60	217
TGLD-3200/3P	785	541	442	360	499	20	56	222
TGLD-3200/4P	1080	655	442	540	613	20	60	222

Note: The shell operating handle is removed normally for all series, and will be used for emergency operation or manual operation.

10 Outline and Installation Dimensions

Please specify the following items when ordering:

11.1 Please specify the product model, current specification, and number of poles when ordering.

11.2 For any special installation conditions or special working site, the corresponding technical information shall be provided by user or contact our company for this.

Example: To order TGLD-100 type, rated current 100A, 4-pole, 1 piece; please specify: TGLD-100/4P 100A 1 piece.