



HR17N/D Fuse Switch Disconnecter

1 Overview

HR17N/D Fuse Switch Disconnecter is used in the AC 50Hz low-voltage power distribution equipment with the rated voltage up to 690V and with the rated current up to 630A and in the power distribution circuit and motor circuit with high short circuit current as power switch, switch disconnecter, and emergency switch; it is generally not used to directly turn on or turn off a single motor.

This product complies with IEC 60947-3 standards.

2 Type Designation

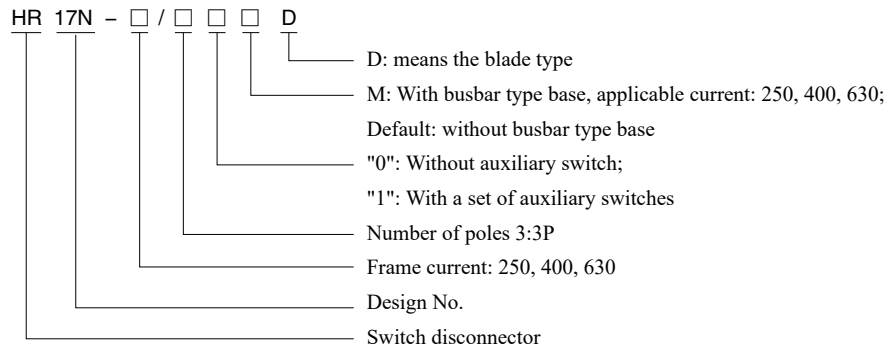

3 Technical Parameters

Table 1

Main technical parameters			
Frame current Ith	250	400	630
Rated operating current Ie (A)	250	400	630
Rated insulation voltage Ui (V)	1000		
Rated operating voltage Ue (V)	AC415/690 50Hz		
Rated impulse withstand voltage Uimp (kV)	12		
Usage category	AC-23B/AC-22B		
Rated short circuit withstand current Icw (kA/s)	10	15	
Rated short circuit making capacity Icm (kA)	17	30	

4 Operating Conditions

4.1 Ambient air temperature

The upper limit of ambient air temperature does not exceed +40°C, and the mean temperature does not exceed +35°C within 24 hours. The lower limit of ambient air temperature is not below -5°C.

4.2 Altitude

The altitude at the installation site does not exceed 2000m.

4.3 Atmospheric conditions

4.3.1 The relative humidity of the atmosphere at the installation site does not exceed 50% at a maximum temperature of +40°C. A high relative humidity may be allowed at lower temperatures, such as 90% at 20°C. Special measures should be taken for condensation occurred occasionally due to temperature changes.

4.3.2 Pollution degree: 3.

4.4 Installation category: III; There is no significant shaking, shock vibration, or rain and snow intrusion at the installation site; there is no explosion hazard medium and there is no gas or dust sufficient to cause metal corrosion and damage to the insulation in the medium at the installation site.

4.5 The product shall be installed vertically, and the position indicated by the indicator end of the handle should be consistent with the product status.

HR17N/D Fuse Switch Disconnecter

5 Features

5.1 Structure

HR17N/D Fuse Switch Disconnecter is primarily composed of a mounting base, a handle, and an anti-electric protective cover. The housing is made of plastic and has advantages of compact structure, light weight, reliable operation, safety, convenient installation, and artistic appearance.

5.2 Aux. switch

The switch can be equipped with an auxiliary switch used to clearly indicate that the switch is in the "ON" or "OFF" position.

5.3 Busbar base

The switch can be equipped with a busbar base, and this base can be installed on the 60mm busbar system with a busbar thickness of 10mm without holes required.

6 Outline and Installation Dimensions

6.1 Installation and outline dimensions for fixed type see Table 2 and Fig. 1

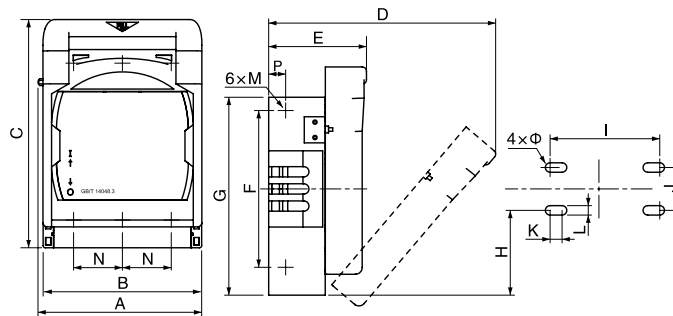

Fig. 1 HR17N/D series fixed type installation and outline dimensions drawing

Table 2

Model	A	B	C	D	E	F	G	H	I	J	K	L	φ	M bolt	N	P
HR17N/ D-250/3D	191	186	267	300	115	183	231	99	128	50	14	11	-	M10	57	22
HR17N/ D-400/3D	214	210	300	330	127	210	252	103	130	50	-	11	11	M10	65	25
HR17N/ D-630/3D	214	210	300	330	127	210	252	103	130	50	-	11	11	M10	65	25

Notes: "F, N" dimensions are the spacing dimension between terminal blocks, and "P" dimension is the distance from the terminal block to the floor.

6.2 Installation and outline dimensions for busbar type see Table 3 and Fig. 2

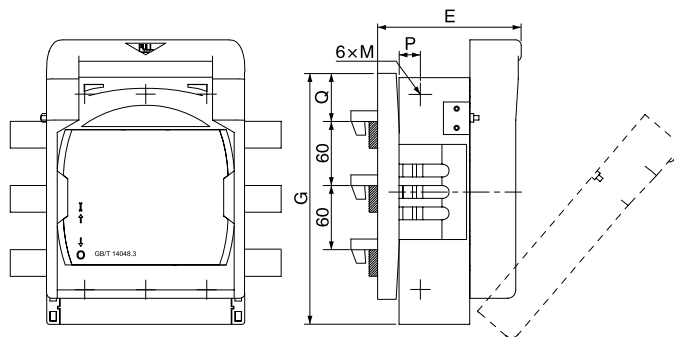

Fig. 2 HR17N/D series busbar type installation and outline dimensions drawing

HR17N/D Fuse Switch Disconnecter

Table 3

Model	E	G	M bolt	Q	P
HR17N/D-250/3D	160	235	M10	69	22
HR17N/D-400/3D	153	264	M10	64	25
HR17N/D-630/3D	153	264	M10	64	25

Note: The busbar type installed product body is same as the fixed type, and the busbar type base is provided on the fixed type product and the same dimensions refer to the fixed type.

7 Product Installation

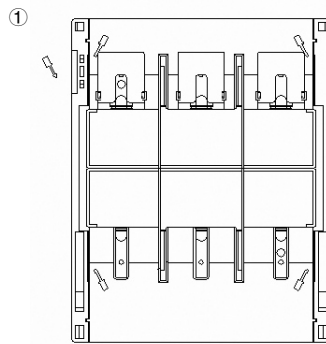

Disassembly of upper and lower protective covers: Insert a small screwdriver into the gap between the protective cover and the base to open the buckle. The upper and lower protective covers are located at four places.

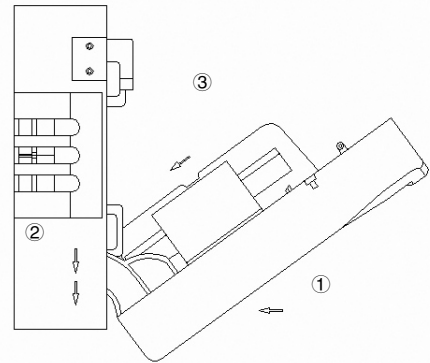

Disassembly of handle and base: When the handle is open in a fan shape, move the handle up to separate the base from the handle;

Installation of handle and base: Insert the handle into the fixed slot on the base, push the handle downwards into the fixed slot on the base, as shown in figures ① and ②;

Installation of fuse: The fuse can be replaced after the removal of handle, and the assembly direction is shown in Fig. ③.

8 Ordering Notice

8.1 Please specify the following information when ordering

Please specify the product name, model, rated operating current, the number of poles, whether the micro switch is provided, whether the busbar type base is provided, and the number of switch when ordering.

8.2 Order example: such as HR17N/D-400/30D 400A 100 units.